

APPROXIMATIVE DATA AND MEASURES

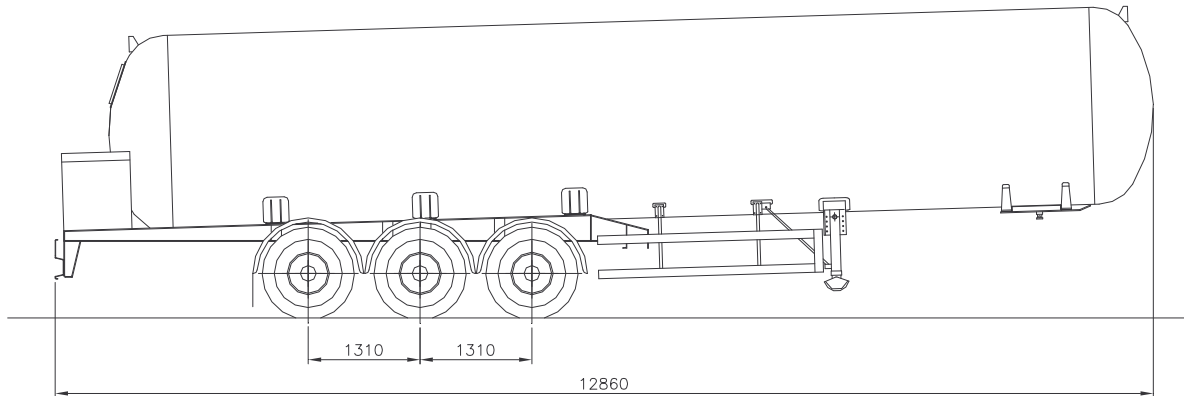

| | |
|------------------------------|--|
| GEOMETRICAL CAPACITY: | 48.000 liters |
| TOTAL WEIGHT: | 34.000 kg (40,000 kg with two axle tractor) |
| DEAD WEIGHT (TARE): | 12.700 kg |

TANK

- Transported gas: propane, butane and mixtures
- Three steel diaphragms
- Test pressure: 27 bars
- Pneumatically operated internal valves for liquid phase (3") and gas phase (2")
- 3" BLACKMER pump driven by hydro-motor
- 2" LIQUID CONTROLS flow-meter with mechanical counter and ticket printer (electronic counter optional)
- External ball valves for liquid phase (DN50) and gas phase (DN40) complete of ACME couplings

SEMITRAILER

- Three axles pneumatic suspension BPW ECO PLUS, 3 x 9 ton, 2 x 1,310 mm, first lifting axle (third optional)
- MICHELIN XTE3 385/65 R 22.5 tyres
- Braking system ECE approved
- EBS system
- Landing gears and 2" JOST king pin
- Rear and side aluminium protection ECE approved
- Stainless steel tool box
- Suspension pressure gauge